



TORNADO 2™



PERFORMANCE

The Tornado 2™ oven evenly and consistently toasts, browns, and crisps food up to twelve times faster than traditional cooking methods, resulting in a high level of throughput without compromising quality.

VENTLESS OPERATION

Integral catalytic converter allows for UL®-certified ventless operation.

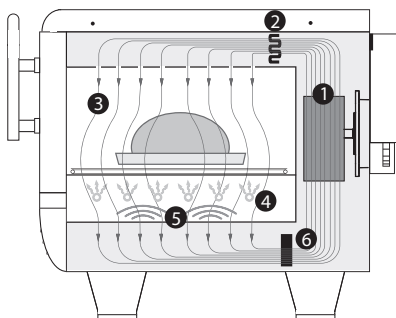

1. Blower Motor
2. Impingement Heater
3. Impinged Air
4. Bottom Browning Element
5. Microwave Bursts
6. Catalytic Converter

Project _____

Item No. _____

Quantity _____

EXTERIOR CONSTRUCTION

- Stainless steel exterior with powder-coated side panels
- 4" (102 mm) legs
- Cool to the touch pull down door with microwave seal

INTERIOR CONSTRUCTION

- 304 stainless steel interior
- Fully insulated cook chamber
- Removable / variable cooking surfaces
- Exposed bottom browning element

STANDARD FEATURES

- Integral recirculating catalytic converter for UL 710B (KNLZ) listed ventless operation
- Variable-speed High h recirculating impingement airflow system
- Variable cooking surfaces (racks, stones, and platters)
- Independently-controlled bottom browning element
- Smart Voltage Sensor Technology* (U.S. only)
- Smart menu system capable of storing up to 128 recipes
- Built-in self-diagnostics for monitoring oven components and performance
- Stackable design (requires stacking kit)
- Manual snooze mode
- Includes plug and cord (5 ft.)
- Smart card compatible
- Warranty – 1 year parts and labor

COMES WITH STANDARD ACCESSORIES

- 1 Aluminum Paddle (103284)
- 1 Bottle Oven Cleaner (103180)
- 1 Bottle Oven Guard (103181)
- 2 Trigger Sprayers (103182)
- 2 Teflon Baskets (100011)



* Smart Voltage Sensor Technology does not compensate for lack of or over voltage situations. It is the responsibility of the owner to supply voltage to the unit according to the specifications on the back of this sheet.

Ultimate ventless allowance is dependent upon AHJ approval, as some jurisdictions may not recognize the UL certification or application. Call to request ventless certification information.

This product conforms to the ventilation recommendations set forth by NFPA96 using EPA202 test method.

TurboChef reserves the right to make substitutions of components or change specifications without prior notice.

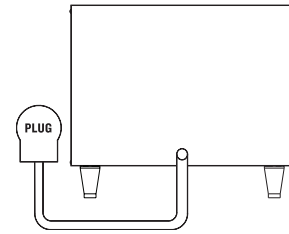
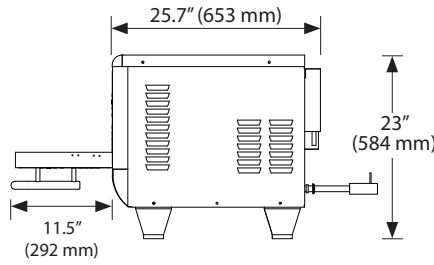
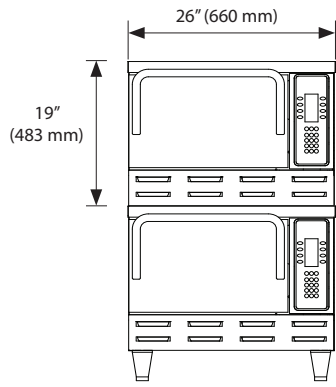

DIMENSIONS		
Single Units		
Height	19"	483 mm
on legs	23"	584 mm
Width	26"	660 mm
Depth	25.7"	653 mm
with handle	28.45"	723 mm
Weight	190 lb.	86 kg
Stacked Units (Stacking Kit Required)		
Height	38"	965 mm
Width	26"	660 mm
Depth	25.7"	653 mm
with handle	28.45"	723 mm
Cook Chamber		
Height	8"	203 mm
Width	15.5"	394 mm
Depth	14.7"	373 mm
Volume	1.05 cu.ft.	29.9 liters
Wall Clearance (Oven not intended for built-in installation)		
Top	4"	102 mm
Sides	2"	51 mm
ELECTRICAL SPECIFICATIONS		
NORTH AMERICA		
NGC (NGC-1280-1)		
Phase	1 Phase	
Voltage	208/240 VAC	
Frequency	60 Hz	
Current	30 amp	
Max Circuit Requirement	30 amp	
Plug/Cord	NEMA 6-30P; 1.5m, H07RN-F	
Max Input	5990/6675 watts	
Microwave Input Power	3500 watts	
NGCBK (NGC-1280-1K-2020)		
Phase	1 Phase	
Voltage	220 VAC	
Frequency	60 Hz	
Current	30 amp	
Max Circuit Requirement	30 amp	
Plug	IEC 309, 3-pin, 32 amp	
Microwave Input Power	3500 watts	
EUROPE/ASIA-PACIFIC		
NGCEW (NGC-1280-1W for standard) NGCEW (NGC-1280-1W-2024 for Australia/New Zealand)* NGCKW (NGC-1280-1W-2004 for South Korea)**		
Phase	3 Phase	
Voltage	400 VAC	
Frequency	50 Hz or 60 Hz**	
Current	16 amp	
Max Circuit Requirement	20 amp	

Plug	IEC 309, 5-pin, 32 amp		
Max Input	10500 watts		
Microwave Input Power	3500 watts		
NGCED (NGC-1280-1D)			
Phase	3 Phase		
Voltage	230 VAC		
Frequency	50 Hz		
Current	30 amp		
Max Circuit Requirement	32 amp		
Plug	IEC 309, 4-pin, 32 amp		
Max Input	10500 watts		
Microwave Input Power	3500 watts		
NGCUK (NGC-12801K)			
Phase	1 Phase		
Voltage	230 VAC		
Frequency	50 Hz		
Current	30 amp		
Max Circuit Requirement	32 amp		
Plug	IEC 309, 3-pin, 32 amp		
Max Input	6700 watts		
Microwave Input Power	3500 watts		
JAPAN			
NGCJD - 50Hz/ 3 Phase (NGC-1280-1D-2005-1) NGCJD - 60Hz/ 3 Phase (NGC-1280-1D-2005-2) NGCJK - 50Hz/ 1 Phase (NGC-1280-1K-2005-3) NGCJK - 60Hz/ 1 Phase (NGC-1280-1K-2005-4)			
Phase	1 or 3 Phase		
Voltage	200 VAC		
Frequency	50 or 60 Hz		
Current	30 amp		
Max Circuit Requirement	30 amp		
Plug	PSE-marked, 3 or 4-blade, 30 amp		
Max Input	10500 or 6700 watts		
Microwave Input Power	3500 watts		
SHIPPING INFORMATION			
U.S.: All ovens shipped within the U.S. are packaged in a double-wall corrugated box banded to a wooden skid. International: All International ovens shipped via Air or Less than Container Loads are packaged in wooden crates.			
Box size: 34" x 30" x 30" (864mm x 762mm x 762mm) Crate size: 36.5" x 32.5" x 31.5" (927mm x 826mm x 800mm) Item class: 85 NMFC #26770 HS code 8419.81			
Approximate crated weight: 310 lb. (141 kg)			
Minimum entry clearance required for box: 30" (762mm) Minimum entry clearance required for crate: 31.5" (800mm)			

*All AU-New Zealand ovens with clips allow for 5 pin plug.
TurboChef recommends installing a type D circuit breaker for all installations.